

LK CubicMeter

DESIGN

CubicMeter is a compact digital water meter for measuring water consumption in residential and commercial properties. It is recommended that one CubicMeter is installed per inlet pipe, i.e. one on the hot water pipe and one on the cold water pipe, in order for the system to cover both lines in case of leaks and to improve the system’s water flow analysis and predictions.

LK CubicMeter is a non-invasive water and leakage meter. LK CubicMeter’s unique design means that it can be installed on existing pipes in the range between 15 - 26 mm with outer diameter and a range of different materials.

According to studies, implementation of individual metering decreases the water consumption with approximately 30%. For a normal average family that decrease not only water consumption, but also carbon dioxide emissions and possible leakage costs.

- Non-invasive water & leakage monitor.
- The LK CubicMeter’s unique design allows it to be installed on existing pipes in the range between 15 - 26 mm with outer diameter and a range of different materials.
- Eliminates the need for ultrasonic gel, which dries out quickly.
- Up to 98 % accuracy & MID/OIML R-49 Compliant.
- Up to ten years of battery life.
- Plug & Play installation with low maintenance
- Compatible with LK Pex and PAL pipes dim. 16 – 25.
- Detection of drip leaks, broken pipes and larger leaks.
- Wireless communication, Wireless M-Bus – Mode C1 868 MHz (EN-13757 Standard)



TABLE OF CONTENTS	
Design	1
Handling and Intended Use	2
Sizing	2
Technical Specifications	2
Wireless Connectivity	3
Markings	3
LCD Codes and Information	3
Principle of Operation	4
Installation Instructions	5
Maintenance and Service	7
Accessories	7



HANDLING AND INTENDED USE



NOTE!

Extra care should be taken when shipping and handling the devices. When receiving the water meters, they should be inspected for obvious possible external damages that may have occurred during transport.



NOTE!

The units are protected against unauthorised tampering through the use of tamper-seal stickers and tamper-seal covers. If any seal/ enclosure is damaged during installation or by other means, the meter is no longer approved for billing purposes, according to MID (Measuring Instruments Directive). The meter must be removed and recalibrated/replaced by an authorized service center.



NOTE!

The units must be handled, maintained, installed and connected using the described methods, so that correct measurements are made and the unit's reliability can be guaranteed.



NOTE!

The CubicMeter is an accurate measurement instrument which requires careful handling. It should not be subjected to impulses nor unreasonable vibrations as this may impair the instrument.



NOTE!

The device should not be left in direct sunlight nor in humid environments. Follow the permitted operating conditions in the **Technical specifications** section.



NOTE!

The water meters should be attentively and individually packaged and protected from these harsh environments and conditions. Recommended storage temperatures are between 15-25 °C.

SIZING

The unique design of the CubicMeter allows it to be installed on existing pipes in the span between 15 - 26 mm of outside diameter, and a range of different materials. Please refer to **Table 1** for the list of materials/thickness handled in this range.

Pipe Material	Pipe Wall Thickness Range
PEX-Alu-PEX/PAL (multi-layer)	1 - 3.5 mm
PEX 1	1 - 3.5 mm
PE-RT 1 - 3.5 mm	1 - 3.5 mm
PVC 1 - 3.5 mm	1 - 3.5 mm
MEPLA (multi-layer)	1 - 3.5 mm

TECHNICAL SPECIFICATIONS

Water temperature:	0.1°C...70°C (T70)
Pressure	PN10 (pipe dependent)
Environmental	B (MID), fixed installation with minimal vibrations
Electromagnetic	E1 (residential, commercial, light industrial)
Climate/environment	5°C...30°C (T70)

Battery	3.6 VDC Li/SOCl ₂ , non-replaceable, up to 10 years
Storage conditions	5°C...55°C
Wireless frequency	868 MHz
Infrared pulse output	1 pulse per litre
Overload flow rate (Q ₄)	3 125 l/h
Drip detection	>0.4 l/h (alerted wirelessly only)
Leak detection	>4 l/h for at least 70 min
Burst detection	>200 l/h first least 35 min
Weight	260 grams
Dimensions	Width: 40 mm, Height: 79 mm, Length 87 mm
Wireless protocol	Labtrino Protocol Wireless M-Bus (C1, format A)



WIRELESS CONNECTIVITY

The CubicMeter communicates using 868 MHz radio frequency which allows the meter to be read remotely using Quandify’s Gateway and cloud solution. Contact Quandify to purchase a wireless gateway for remote data collection and visualisation, if you do not have it already. Download the installation guide for the gateway here: https://labtrino.com/product-documents/gateway/LT-GW_manual.pdf.

The CubicMeter also communicates with the open wireless M-Bus standard using 868 MHz mode C1, format A and security mode 5.

To receive the individual meter encryption key, please fill in the form here: <https://labtrino.com/cm1-key-request-form/> using your purchase receipt. The meter can then be used with most standard wireless M-Bus gateways.

Protocol information Quandify’s registered DLMS ID is “LTO” and the protocol follows EN-13757 for sending total volume usage data. The leakage status alarm can be parsed from the “meter status byte” at bit 6 (0x40), 1=leak, 0=no leak.

Meter Status

Bit	Value for Single Error (Hex)	Name According to EN 13757-3
0	00h 01h	No error Application busy
1	02h 03h	Any application error Abnormal condition/ alarm
2	04h	Low power
3	08h	Permanent error
4	10h	Temporary error
5	20h	Specific to manufacturer
6	40h	Specific to manufacturer
7	80h	Specific to manufacturer

The Status Byte may have more than one error bit set at any time.

MARKINGS

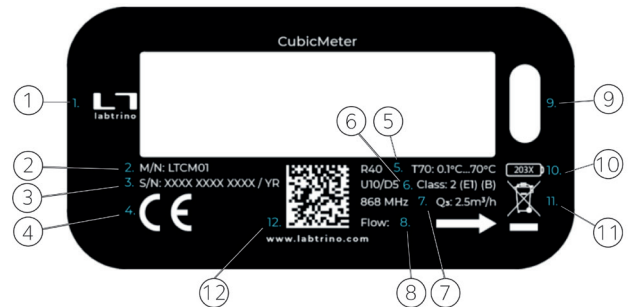

1. Company logo
2. Model number
3. Serial number and manufacturing year
4. CE mark
5. Dynamic range and temperature class
6. Velocity field, accuracy and environmental class
7. Radio frequency and max flow rate value (Q3)
8. Flow direction
9. Optical communication
10. battery expiration year
11. WEEE Directive
12. Website and data matrix of S/N.





LCD CODES AND INFORMATION



The LCD Display.

LCD Code	Description
TAMPER	Attempt to fraud or in other ways affect the meters. The meter is no longer approved for billing by MID.
LEAK	Possible leakage detected.
REVERSE	Water is flowing through the meter in the wrong direction.
BURST	Possible pipe burst detected.



LCD Code	Description
NO SENSING	Unable to detect water. May be due to the pipe not being filled with water, or loosely installed meter. Flow is not measured.
	Indicates the momentary direction of the flow (left or right).
	Indicates a faulty metering device, or signals a warning in conjunction with an error/warning code.
	Indicates successful radio transmissions. A single dot indicates a faulty radio module.
	Low battery, less than 180 days remaining.

The units perform an LCD check every 5 minutes where all segments are displayed for a visual verification of the LCD screen’s full functionality.

The following information is then displayed in the following order:

1. Firmware version
2. Firmware checksum in hex format
3. Serial number in hex format
4. Current water temperature in °C
5. Pipe setting
6. Event(change) log counter
7. If applicable, the last error logged.

PRINCIPLE OF OPERATION

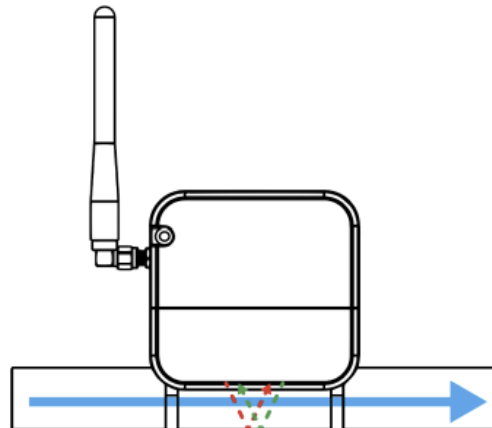

The CubicMeter measures the flow of water with the use of ultrasonic waves and the “differential time of flight” method. To measure the flow of the water, two ultrasonic transducers transmit signals in opposing directions through the pipe and water as illustrated in the above image.

The signal sent by the upstream transducer will travel along the direction of water flow before being detected by the downstream transducer. The second signal, sent by the downstream transducer will travel against the direction of water flow, and therefore will advance slower, and arrive measurably later at the upstream transducer.

The difference in travel time of the two signals is proportionate to the speed of water in the pipe, and with that, proportionate to the flow rate in the pipe. A simple analogy to this would be swimming in a current of water. One can estimate the speed of the water flow in a river, by swimming upstream and downstream and comparing the time it took to travel the same distance in each direction - the faster the river flow, the bigger the difference in time will be. In the case of the CubicMeter, the swimmer is replaced with a wave caused by the movement of transducers.

The probing signal has a frequency of 1 MHz and at a very low power. Sounds of this frequency are inaudible and harmless to humans and animals. Moreover, acoustic waves of this high frequency are strongly attenuated by atmospheric pressure air, and in practice cannot travel beyond the pipe. There should therefore be no concern about the CubicMeter interfering with other devices.



INSTALLATION INSTRUCTIONS

Since the meter is non-invasive, there is no need for check valves nor shut-off valves. The need for these items is regulated according to local regulations. No strainer is required before the meter under normal conditions.



NOTE!

If the meter is installed where connectivity is poor, e.g. in a reinforced concrete basement or in a metal locker, it may be necessary to supplement it with an additional gateway to ensure optimal communication.

It is highly recommended that one installs the gateways in close proximity to the meters. Avoid installing the unit where it may be subjected to direct sunlight.



NOTE!

When installing the meter, the unit may require the larger sized clamps in the pipe span between 20-26 mm to be installed. **Make sure the pipe is straight.**

Optional

If you want to avoid tampering, the tamper-seal sticker and tamper-seal covers can be attached to the enclosure after complete installation.

TORQUE!

0.4Nm

When installing, it must be ensured that the mechanical tension between the pipe and the meter is not higher than necessary. The fastening clamps may be tightened with the following **torque: 0.4Nm. Do not over-tighten.**

The CubicMeter can be installed in any position and at any angle. The meter can be installed vertically on an incoming pipe, at any angle and even with the display facing down, e.g. in a ceiling. The pipeline on which the CubicMeter is installed should be designed/shaped so that the risk for air-buildup is eliminated. It is recommended that the piping system is fully filled with clean water without air-bubbles. If air is detected, the instrument will send and display an alarm.

See the image for suggested installation positions. For optimal flow accuracy, the CubicMeter should have a straight pipe length of 10x the pipe inner diameter upstreams (U10) or more, and 5x the pipe inner diameter downstreams (D5).



NOTE!

To be able to detect small leakages, ensure that there are no current leakages upon installation and for the coming 24 hours of continuous zero-flow.

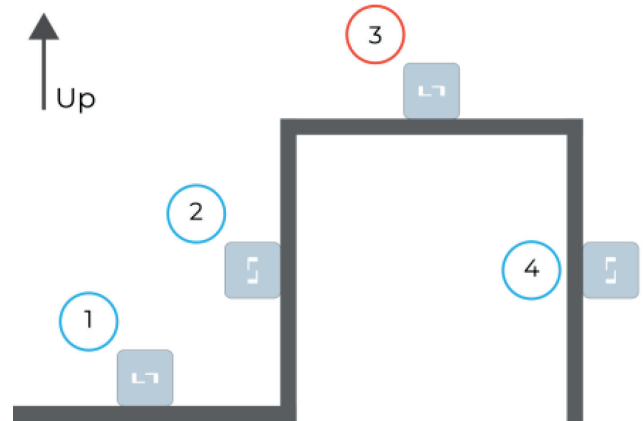

1. *Acceptble* water meter position.
2. *Acceptable* water meter position.
3. *Not rcommended* water meter position. Air build-up may occur.
4. *Acceptable* water meter position.

Make sure that the installed CubicMeter is parallel to the pipe on which it is to be installed. The right image shows a correct installation, whereas the left image illustrates a non-parallel and faulty installation. Water should flow through the water meter in the direction indicated by the flow arrow near the display.

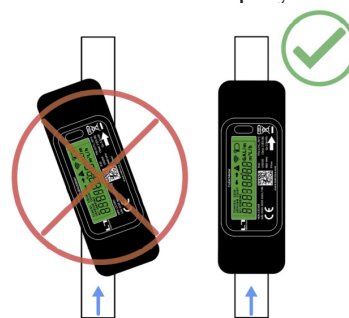

See the installation video guide [CubicMeter Installation Guide - YouTube](#)



Install CubicMeter

1. Screw on the antenna.
2. Attach the two fastening clamps around the pipe so that they hang freely on the pipe.
3. Place the CubicMeter between the two fastening clamps, with the flow arrow in the same direction as the flow direction.

0.4Nm

NOTE!

Do not turn/move the unit after the clamps have been engaged, as it will damage the unit. Slide the fastening clamps into their designated areas on the CubicMeter and screw them with a **torque of 0.4 Nm. Do not over-tighten.**

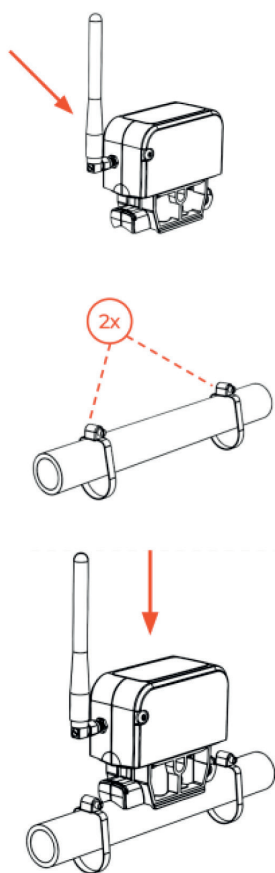

The illustration shows the first three steps in the installation process.

4. Remove the *activation-sticker* from the display.
A counter will be displayed, and after about 10 seconds has passed, the LCD will switch between showing the current flow rate (l/h) and the selected pipe. To switch pipe setting, hold the activation sticker over the infrared eye until the correct pipe has been chosen.

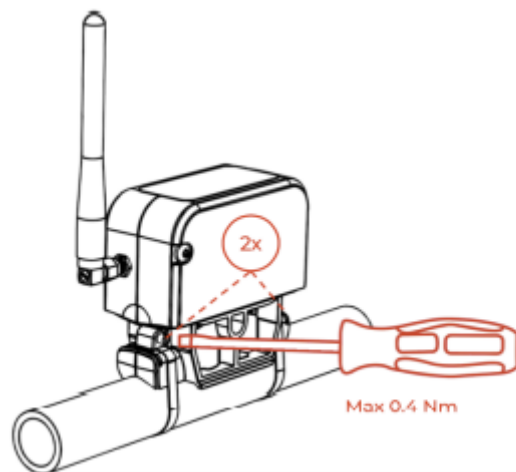

The illustration shows how to remove the sticker.

5. The device will then “activate” automatically after 8 hours.

NOTE!

If the *activation sticker* is put back on for 15s over the infrared eye within 8 hours after the sticker has been removed, the device will revert to its package state.

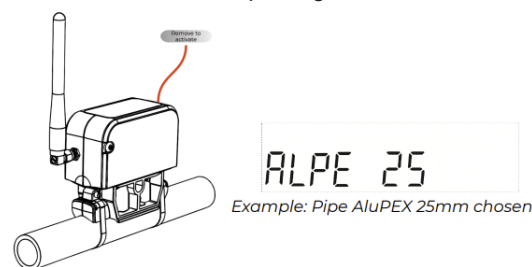

LCD code	Compatible pipes
ALPE XX	AluPEX (multi-layered) pipes
MEPL XX	GEBERIT MRPLA pipes
ALPE XX	PEX or PVC pipes



Optional

- If tampering seals are needed, finish the installation process by attaching a tamper-seal sticker in the designated area. Attach the two tamper-seal cover lids on each side of the CubicMeter.

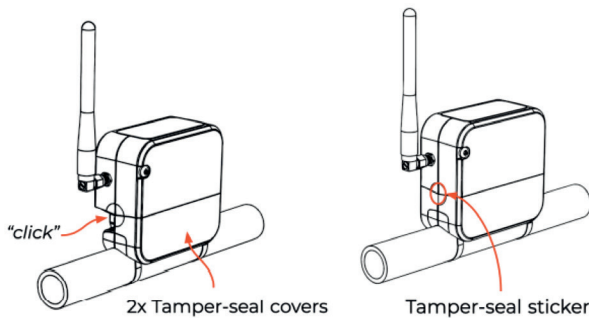
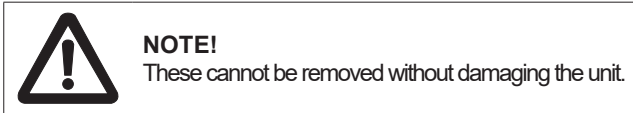

Tamper-seal cover lids and tampering seals.

MAINTENANCE AND SERVICE

CubicMeter is maintenance-free throughout the life of the meter, which is up to 10 years. Check the LCD display for any warnings or error messages. A list of error/warning codes and its meaning is available here: <https://labtrino.com/product-documents/cubicmeter/error-codes.pdf>. If a unit is faulty, contact support for further assistance.

It is not possible to service it without damaging the enclosure. This means that all service, including battery replacement must be performed by an authorized *Quandify service center*. Contact *LK Systems support* <https://www.lksystems.se/en/support/>.

Some configuration options can be performed via the meter's built-in optical eye by authorized personnel. If external parts need to be replaced, such as antennas or clamps, only original manufacturer spare parts should be used. Replacements should only be done by authorized personnel.

Uninstall

- To uninstall a meter from a pipe, use a screwdriver to bend away the two tamper-seal covers until it breaks and can be removed.
- Use pliers to cut the two metal fastening clamps around the pipe.
- The meter can then be removed.
- Contact support at support@quandify.com for assistance or *contact LK Systems support* <https://www.lksystems.se/en/support/>.

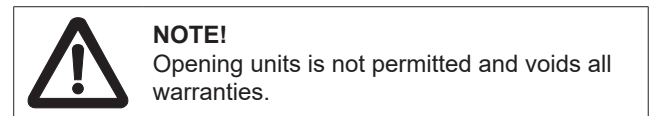

Package Contents

The standard parts included in the package are :

- CubicMeter (LTCM-0X).
- 1x CubicMeter 868MHz Antenna.
- 1x Small Stainless Steel Clamps (for 15-20mm pipe).
- 2x Large Stainless Steel Clamps (for 20-26mm pipe).
- 2x Tamper-Seal Covers.
- 2x Tamper-Seal Stickers.
- 2x Activation sticker (remove to activate).
- 1x Additional parts (not included): CubicMeter Gateway (for wireless data collecting)
CubicMeter Gateway 868MHz antenna
CubicMeter Gateway 5V DC power adapter
CubicMeter Gateway 4G antennas for cellular connection.

ACCESSORIES

LK Distance Pipe Article number: 188 26 66

