

# LK Bending tool PAL 16, 20, 25, 32 and 40

These instructions are for LK Bending tool PAL for dimensions 16 , 20, 25, 32 and 40. Each tool is clearly marked with the pipe dimension it is intended for. The bending tools for dimension 32 and 40 also have a lug so you can easily attach them in a screw vise.

**NOTE!** The tools are only intended for work on LK PAL pipes.

Art no 187 81 75	LK Bending tool PAL 16
Art no 187 81 76	LK Bending tool PAL 20
Art no 187 81 77	LK Bending tool PAL 25
Art no 188 10 68	LK Bending tool PAL 32
Art no 188 10 69	LK Bending tool PAL 40



## 90° BEND

Figure 1 shows how the correct distance is obtained between the end of the pipe and the centre of the bend with a 90° bend.

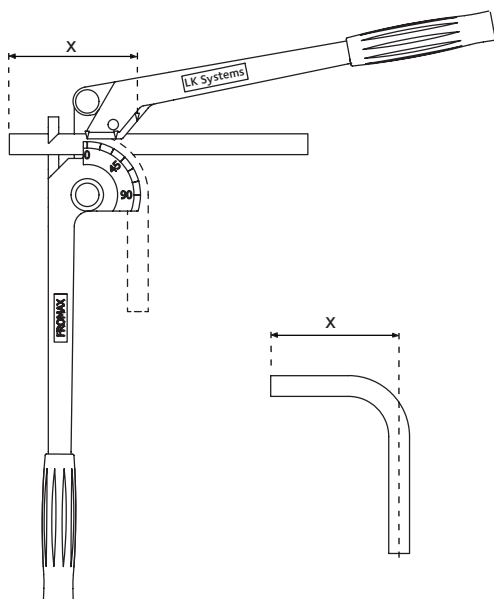

Fig 1.

Figure 2 shows how the correct distance is obtained between the end of the pipe and the centre of the bend with a 90° bend.

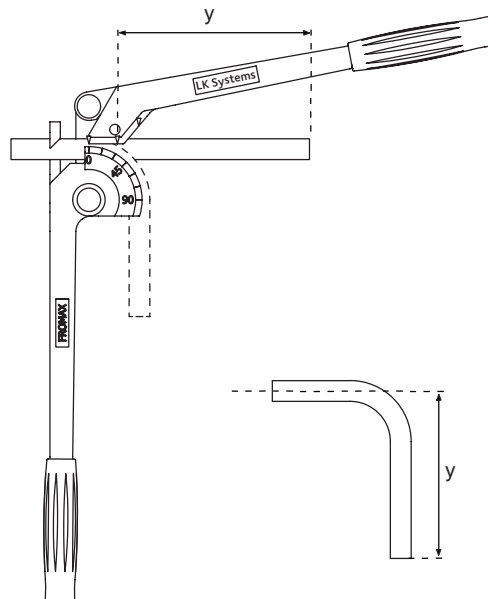

Fig 2.

## S BENDS

The first 90° bend is made as in figure 1 or figure 2. The centre position of the second 90° bend is based on its distance from the first 90° bend.

## S BENDS THAT ARE CLOSE TOGETHER

Firstly, a 45° bend is made. Turn the pipe through a half turn, as in figure 3, and make a 45° bend. The dimension between the bend centres X is obtained on the basis of the segment's outside diameter and by moving the pipe back and forth in the tool. NOTE! The dimension X decreases if the bend is less than 45°.

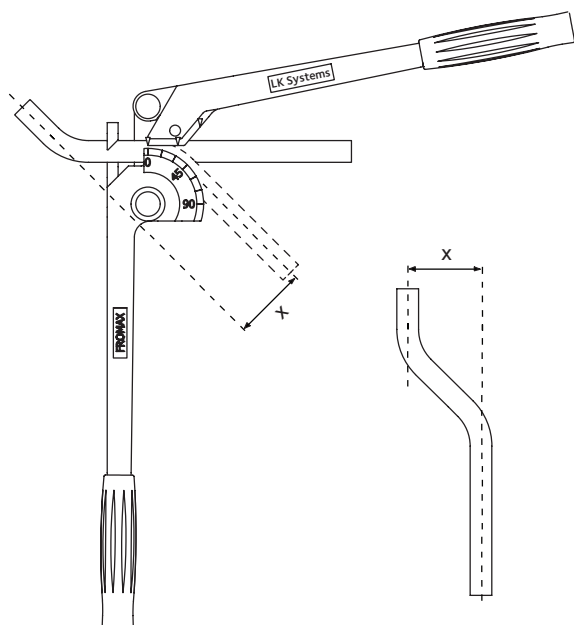

Fig 3.

## SADDLE BENDS

1. The first bend is made at, for example, 45°.
2. Turn the pipe through a half turn and make a 90° bend.
3. Turn the pipe through a half turn again and make a 45° bend. When the final 45° bend is made, the centre line of the pipe must align with the outside diameter of the segment.

NOTE! The largest saddle bend is obtained if the first bend is made at 45°. The size of the saddle bend is reduced if the angle of the first bend is reduced.

Bends one and three must have the same angle. The angle of bend two must always be twice as large as the angle of bends one and three.

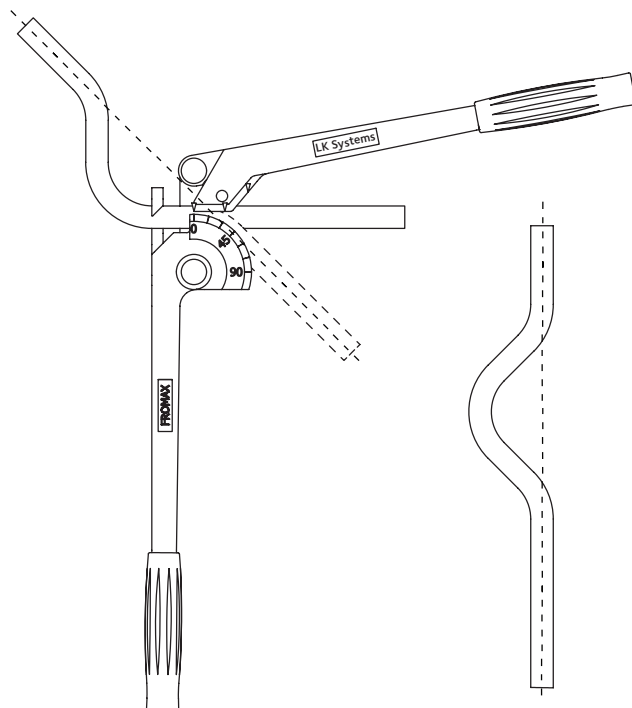

Fig 4.

Figure 4 shows a saddle bend of 45°.