

# LK Heater 350

## DESIGN

LK Heater 350 is an electric comfort heater for floor heating installations performed with LK Minishunt M60n. LK Heater 350 makes it possible to have warm floors in the summertime in single rooms (for example bathrooms) when the house's regular heat source is turned off. When the heating season starts the electric comfort heater shall be turned off and the area is heated by the house's regular heat source.

The heater consists of an electric cartridge installed in a brass tube. The electric cartridge is controlled by an electronic controller for the constant regulation of the water temperature. The product is sold complete for 1 or 2 heating circuits in 12 or 16 mm pipe dimensions. The electric cartridge power is 350W and is sufficient under normal conditions for floor heating surfaces up to 12 m<sup>2</sup>.

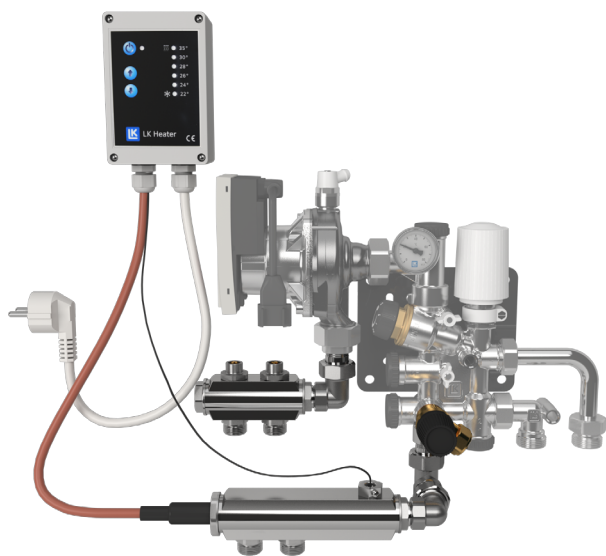

*The image shows the components to LK Heater 350 for two heating circuits. In the image LK Heater is assembled to LK Minishunt M60n which is shaded in the picture.*

## FUNCTION

On the controller the max water inflow temperature can be set up, from 22 °C to 35 °C.

The LK Heater can also be put in frost protection mode with an adjustable water temperature to 10 °C. Key down the temperature setting to 22 °C, and press one more time so that the light for 22 °C flashes indicating frost mode, 10 °C water temperature.



## INSTALLATION



**Note! LK Heater 350 should only be mounted together with the LK Minishunt M60n.**

The control unit is mounted in direct proximity to the Minishunt installation. Fix the electrical cables to the heater plus other cables in the near surrounding to ensure that no cables can come in contact with the housing of the heater brass tube. Mount the supplied safety valve in the Minishunt outlet according to the image below. The safety valve is fitted with a self-sealing O-ring. The safety valve also has a so called metallic seal which can make it seem as if the valve is "slow" to install.

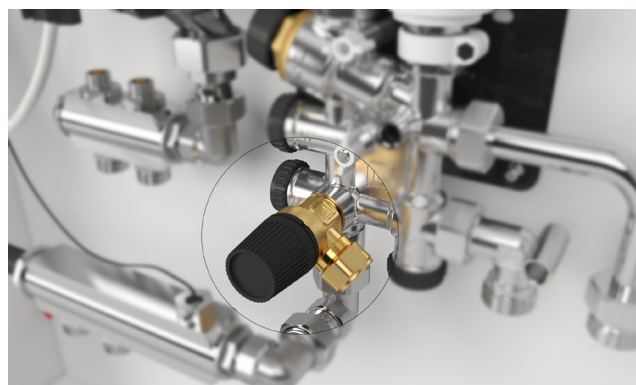

Ensure that the inflow sensor is located in the brass tube's well pockets. The sensor should be clamped with the clamping screw.



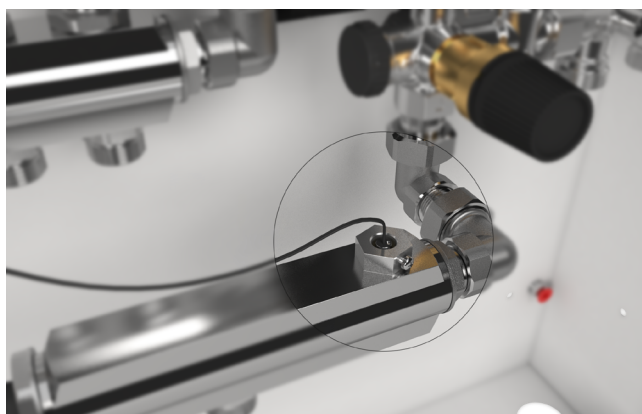

**Note! The inflow sensor should always be installed and connected during operation.**



### OPERATION

The system should be filled and deaerated, see related instructions for the LK Minishunt. The pump should be deployed.

 **Note! The pump should always be on to ensure the cooling of electric cartridge which could otherwise become overheated.**

 **Note! Ensure that the bleeding is done and that the manifold with an electric cartridge is mounted horizontally. Otherwise, electric cartridge may become overheated.**

Connect the control unit's power cable to a grounded outlet (in the case of a blackout, the set temperature is stored in the controller's memory). Set the desired water temperature. Turn down the minishunt thermostat to the bottom so that the valve closes "properly" in relation to the rest of the heating system.



 **Note! The Control Unit's power cable shall be connected to a grounded socket power outlet.**

### Installation of more than two heating circuits

In cases where more than two heating circuits are to be connected, the LK Heater 350 can be screwed together with the LK Mini Manifold.

Note, however, that the maximum floor heating surface for the LK Heater is 12 m<sup>2</sup>. The floor heating circuits that are not being supplied by the heater are turned off via the inflow valves on the LK Mini Manifold. For more information on performance please contact LK Technical Support.

### TROUBLESHOOTING

#### The floor is not warm.

- Start the control unit by pressing the *Turn-on* button and setting the water temperature.
- Check that there is current, the red light on the *Turn-on* button should be constantly lit.
- If the red light next to *Turn-on* button flashes, this may indicate a defective electric cartridge or a triggered overheating protection. Triggered overheating protection is restored by removing the current to the control box for at least 10 sec. Note that the reason for failure should always be investigated before restarting the system.
- Check that the pump is on.
- Check that the minishunt return valve is open and in the case of an inflow divider that its circuit valves are open.
- Increase the temperature until the floor heating temperature feels comfortable.

 **Note! To cut power to the control unit the cable must be unplugged.**

### TECHNICAL DATA

Article no. 241 91 18	LK Heater 1-12
Article no. 241 91 19	LK Heater 1-16
Article no. 241 91 20	LK Heater 2-12
Article no. 241 91 21	LK Heater 2-16
Power controller	360W (of which electric cartridge 350W)
Voltage	230 V AC
Frequency	50 Hz
Temperature setup	22-35 °C
The overheating protection.	Triggers at 93 °C
Frost protection setting	10 °C
Temperature sensor	NTC
Enclosure class control unit	IP 44
Enclosure class cartridge	IP 54
Max. operating pressure	0,20 MPa

Opening pressure Safety valve	0,25 MPa
-------------------------------	----------

## DIMENSIONS

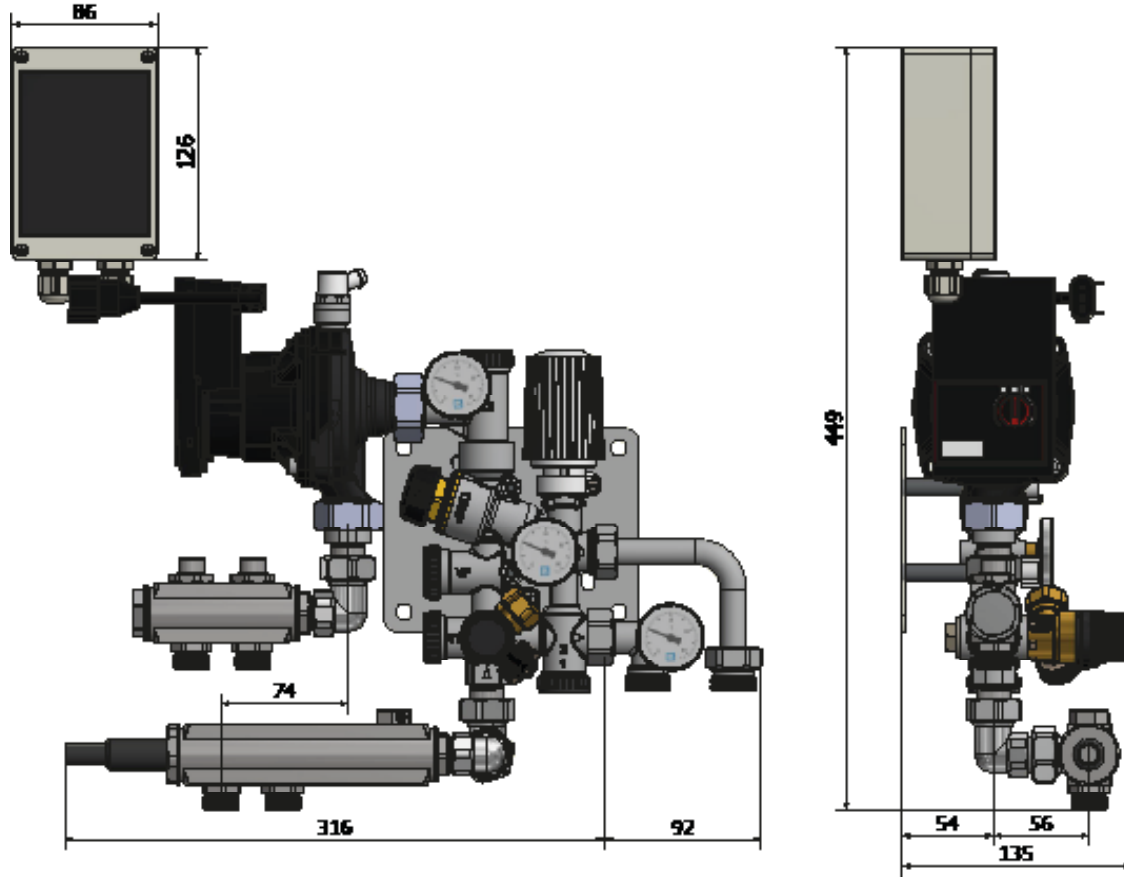

*LK Heater for a single floor heating circuit assembled with LK Minshunt M60n.*