

# LK Heat Exchanger Pack 10 -n2

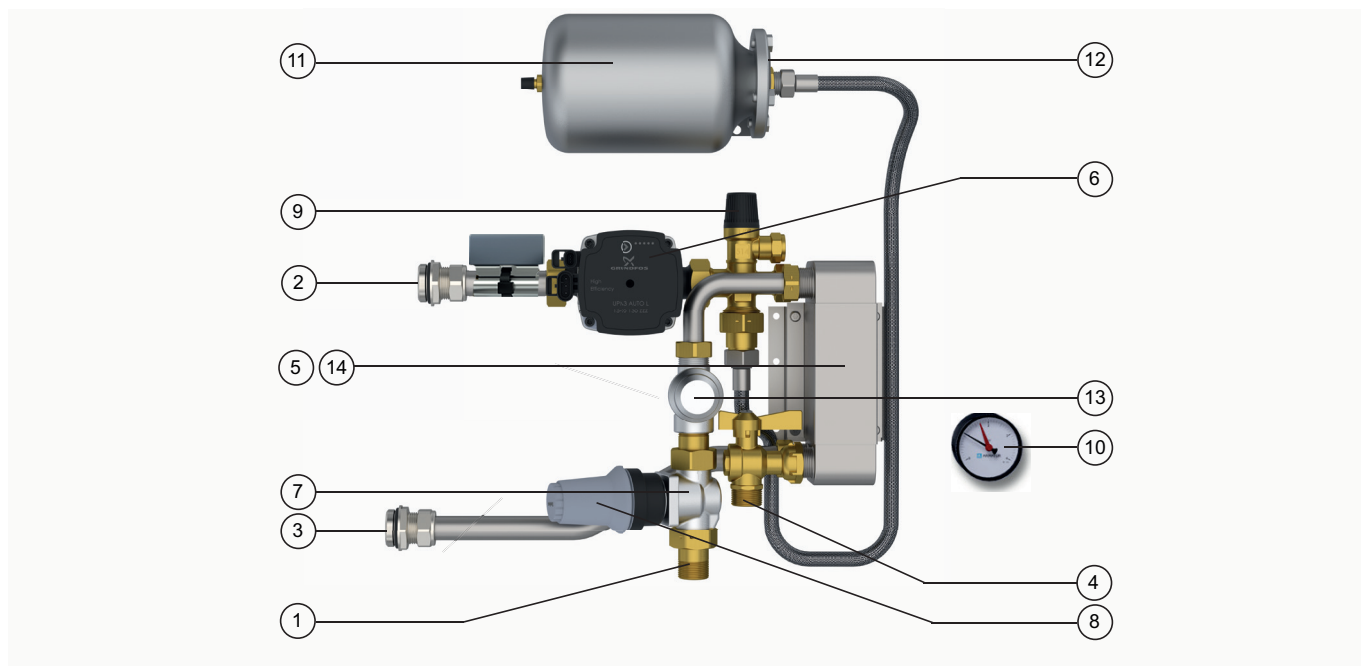

## DESIGN

The LK Heat Exchanger Pack -10 is primarily designed for glycol based under floor heating systems that must be isolated from other heating systems. Such heating systems are used in garden, summer houses or garages, i.e. in areas where the maintenance of a minimum temperature is required during the winter or, can be completely closed off without the risk of the under floor heating system being damaged by freezing. The LK Heat Exchanger Pack is also suitable for small snow melting systems, for instance car ports, short drives, pathways, etc.

## CONSTRUCTION

The LK Heat Exchanger Pack is a ready assembled unit complete with heat exchanger, circulation pump, manometer, expansion vessel, filter and a control valve with automatic thermostat and sensor connected via a capillary tube. The control valve has settings for variable Kv values to adjust to the size of the project. The Heat Exchanger Pack is constructed so that it can be mounted directly to the right side of LK Heating Manifold RF.

1. Primary supply pipe. Connection 3/4" male.
2. Secondary supply pipe. Connection 1" male.
3. Secondary return flow pipe. Connection 1" male.
4. Primary return flow pipe. Connection 3/4" male.
5. Heat exchanger. Compact exchanger in stainless steel and copper.
6. Circulation pump. Grundfoss UPM3 Auto 15-70.
7. Control valve. Adjustable Kv-values up to 2,6/3,2 (see section: Control valve).
8. Thermostat with sensor connected via capillary tube. Operating temperature range 15-50° C.
9. Safety valve 2,5 bar Cu 15.
10. Manometer (installed on the Heating Manifold end cap).
11. Expansion vessel - 2 litre.
12. Bracket, expansion vessel.
13. Filter.
14. Wall Bracket.

## REQUIREMENTS

Before assembly, the heating system must be flushed and should not contain any impurities or additives which can damage the LK Shunt. Maximum 50% glycol mixture.

## CONNECTING TO UNDER FLOOR HEATING

The LK Heat Exchanger Pack is, preferably, connected direct to LK Heating Manifold RF. The LK Heat Exchanger Packs adjustable thermostat (range 15° - 50 °C) maintains a constant temperature for the under floor heating. The Heating Manifold must be controlled by room temperature controls (thermostats). The control valve thermostat can be replaced with LK Control v.3 -RA (electronic weather compensation heat regulation) to control the supply temperature. An LK Control v.3 -RA set is: supply temperature sensor, outdoor sensor, valve actuator and programmable control unit. Where other regulating controls are used, LK can supply 230V or 0-10V valve actuators; contact LK Technical Support for more information.

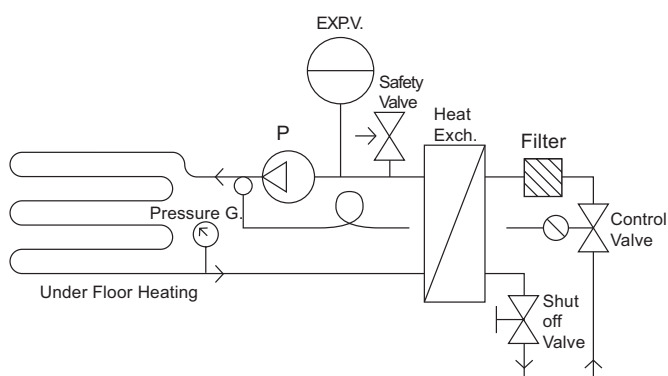
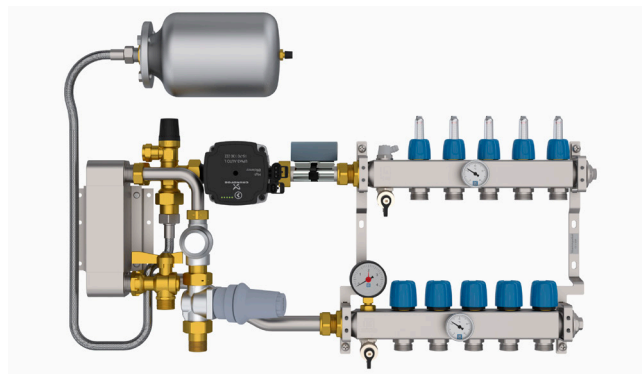

Standard connection to under floor heating with a constant output temperature regulated via thermostat and supply sensor.

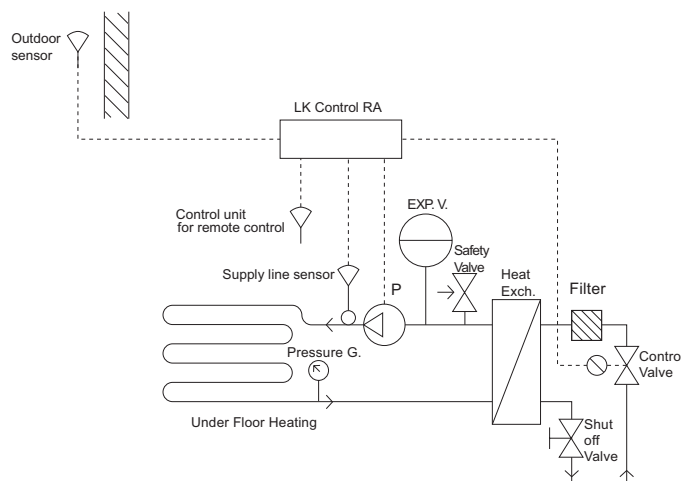

Connection, LK Control v.3 RA with outdoor temperature dependent flow temp.

## CONNECTION TO A GROUND HEATING/ SNOW MELTING SYSTEM

The LK Heat Exchanger Pack is, preferably, connected directly to LK Heating Manifold type RF. If the LK Heat Exchanger Pack is connected to waste heat ("free heat") the supply temperature is controlled via the thermostat (15°-50°C). The sensor is mounted on the secondary supply. The heat exchanger pack can also be set to intermittent operation as required. The heat exchange pack is then completed by using LK Control for snow melting by use of both its ground sensor for ice and snow and its sensor for temperature and moisture. LK Control then starts and stops the pump as per the heating requirements. For further information see the separate information sheet LK Control Unit. With intermittent operation the thermostat's sensor is mounted on the primary return flow for constant monitoring of the return flow temperature. If another brand control system is being used LK can supply either 230V or 0-10V valve actuators - contact LK Technical Support for more information.

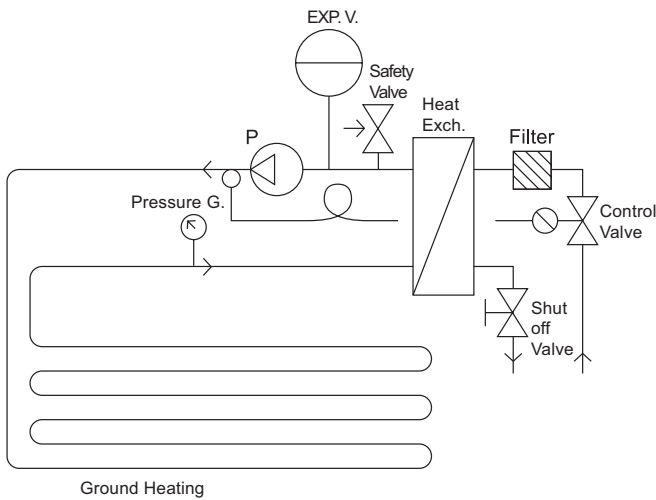

Simple connection of snow melting system with thermostat for constant output temperature. For example used with waste heat.

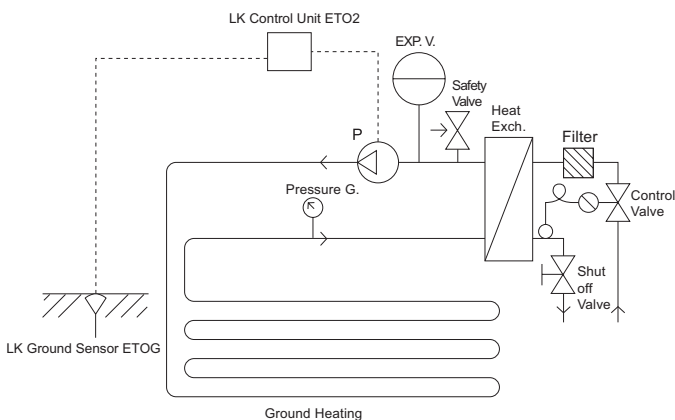

Intermittent control and assembly for snow melting using the LK Control Unit with ground-sensors.

## FROST PROTECTION

If there is a risk of freezing the system, protection must be used. For example, systems in summer or garden houses, glazed verandas etc. were it is possible that the heating may be turned off during the winter or where the exchange pack is used for snow melting systems. The primary flow to the exchange pack must not be restricted or shut off, as this will increase the risk of freezing in the heat exchanger. The secondary flow should be protected from freezing with glycol using the mixing instructions supplied by the manufacturer.

## CONTROL VALVE

Danfoss 2-way control valve RA-C 20 with default (pre-set) valve capacity. The valve capacity is adjusted by lifting the valve's shell ring and turning it to the required setting 1, 2, 3 or N. On the "N" setting the valve is completely open. Anything outside these settings should not be used (indicated by dotted lines).

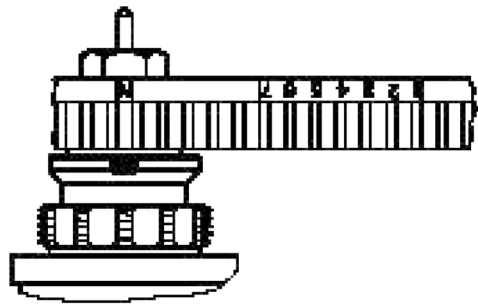

Max differential pressure	60 kPa
Max working pressure	6 bar

## Capacity table

Installation	With thermostat	With valve actuator
1	Kv 0,80	Kv 1,33
2	Kv 1,10	Kv 1,80
3	Kv 1,70	Kv 2,28
N	Kv 2,60	Kvs 3,16

## THERMOSTAT

Danfoss FTC thermostat with a strap on sensor for mounting on the supply pipe of the secondary side. The temperature range settings are 15°-50°C. The supply temperature is dependent on outdoor temperature (and other factors), thus some adjustment of supply temperature during heating season may be necessary. As a guideline the following flow line temperatures can be used: In spring or autumn approx. 35°C and in winter approx. 45°C. The maximum primary temperature is 80°C.



## FILTER

The LK Heat Exchanger’s primary side is fitted with a filter to protect the exchanger from particles, dirt, etc. in the primary water. Cleaning of the filter should be carried by scheduled routine. After being installed it is recommended that the filter be cleaned after a few months in operation. The intervals between cleaning after that must be increased depending upon the extent of impurities in the filter. Isolate the filter by shutting off the control valve using the thermostat head and turn off the ball valve on the primary return side. Unscrew the top of the filter and take out the filter cartridge. Use washing-up detergent or soapy water to cleaning the cartridge.

## Circulation pump

The circulation pump has automatic speed control, which reduces power consumption and gives a quieter operation as the pump adjusts the flow according to the requirements of the system. A cast arrow on the pump housing indicates the direction of the flow. For underfloor heating it is recommended that the pump is set to constant pressure control, see capacity diagram below. Select the constant pressure curve which best matches the design system flow and pressure drop, choose between the curve CONST. PRESS. CURVE 1, 2 or 3.

	CONSTANT PRESSURE 1	
	CONSTANT PRESSURE 2	
	CONSTANT PRESSURE-3 MAX	



QR code for the installation instructions for UPM3

**Note!**

Ensure that the pump never runs dry and the system is well vented before use.

## Operating mode

Grundfos UPM3 Auto indicates in normal operation which setting is currently in use by the pump. Read the selected mode by studying the settings menu below.

## Settings

To change the pump setting press the arrow button on the pump, and the pump will show the selected setting in accordance with the settings menu.

## Settings menu

	OPERATING PANEL	CONTROL MODE	
0		PROPORTIONAL PRESSURE AUTO ADAPT	
1		CONSTANT PRESSURE AUTO ADAPT	
2		PROPORTIONAL PRESSURE 1	
3		PROPORTIONAL PRESSURE 2	
4		PROPORTIONAL PRESSURE 3 - MAX	
5		CONSTANT PRESSURE 1	
6		CONSTANT PRESSURE 2	
7		CONSTANT PRESSURE-3 MAX	
8		CONSTANT CURVE 1	
9		CONSTANT CURVE 2	
10		CONSTANT CURVE 3 - MAX	

Overview of settings options for the UPM3. Relevant settings are marked with a blue rectangle, other settings are shaded.

## Electrical connection

The electrical connection is easily set up with the accompanying plug, with built-in strain relief. The plug no longer requires a 2-pole switch disconnecter. The circulation pump has built-in thermal motor protection. The electrical connection must be fused with Max. 10 A slow blow fuse.



## Capacity chart

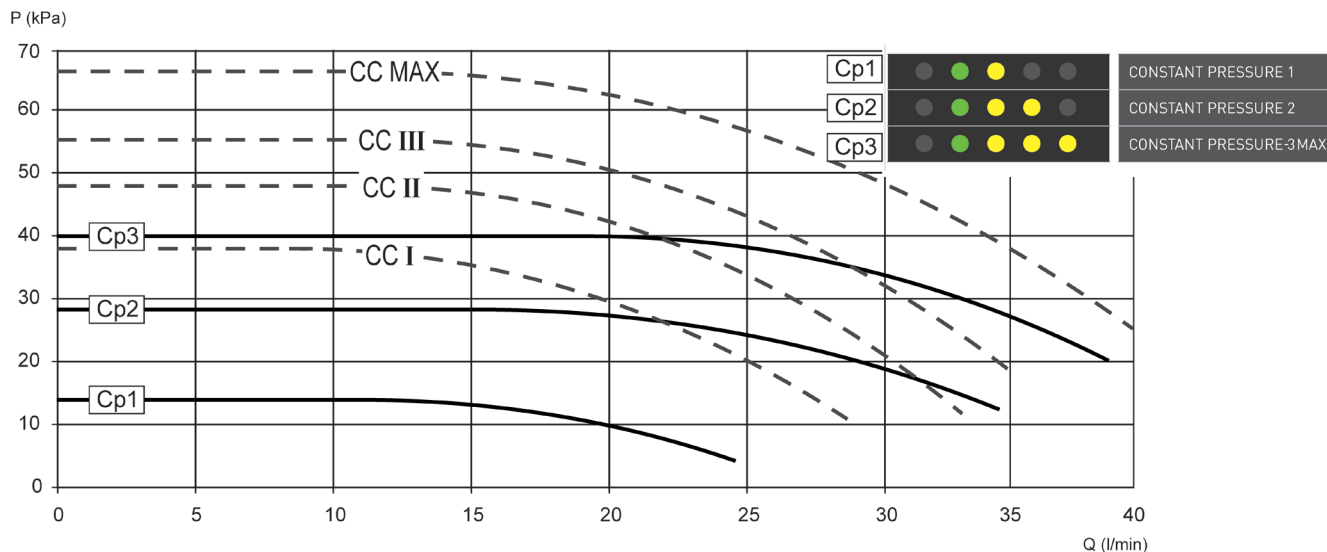

## Alarm codes

In the event of an operating problem then a fault code will be displayed as below.

Display	Indication	Operation	Action
Red LED, Yellow LED #5	Blocked rotor	Start attempt each 1.33 sec.	Wait or re-lease rotor/
Red LED, Yellow LED #4	Too low voltage	Only warning, the pump operates as normal	Check the voltage to the pump
Red LED, Yellow LED #3	Electric fault	Pump stopped because of low voltage or serious fault	Check voltage to pump / Replace pump/ impeller*

*\*Release impeller using screwdriver PH2. Break the voltage to the pump. Insert the screwdriver into the center hole of the drive side, press the screwdriver in about 5 mm, then rotate forward /backward until the impeller loosens.*

## EXPANSION VESSEL

The expansion vessel is fixed to the wall with the wall fastenings supplied. The expansion vessel is connected using the flexible tube (L= 750 mm) supplied with the kit.

## SAFETY VALVE

The safety valve outlet should be set up securely to current regulations. Connection outlet Copper 15 mm. The safety valve should be tested by manually opening it 1-2 times per year.

## MANOMETER

The pressure gauge is installed in the place for the manual air vent on the manifold, alternatively in the manifold end cap, connection G15.

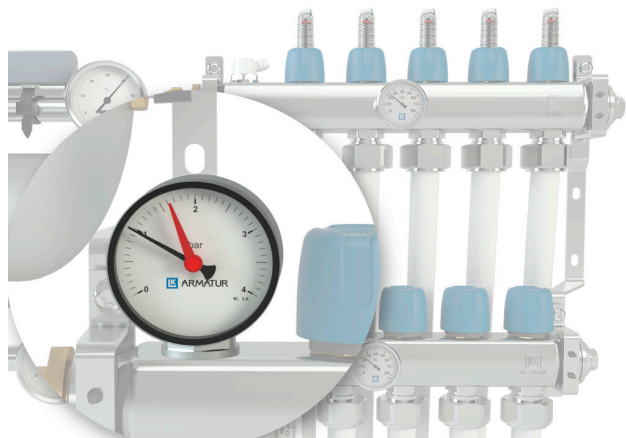

## LK MANIFOLD CABINET

The heat exchanger pack can be placed in LK Cabinet VVX W800 x H710 x D145 mm. The cabinet can hold LK Heat Exchanger Pack 10-n2 and LK Manifold RF up to size 5. The cabinet can be installed on the wall or inside the wall.

For more information see the product range LK Installation Cabinets for underfloor heating.

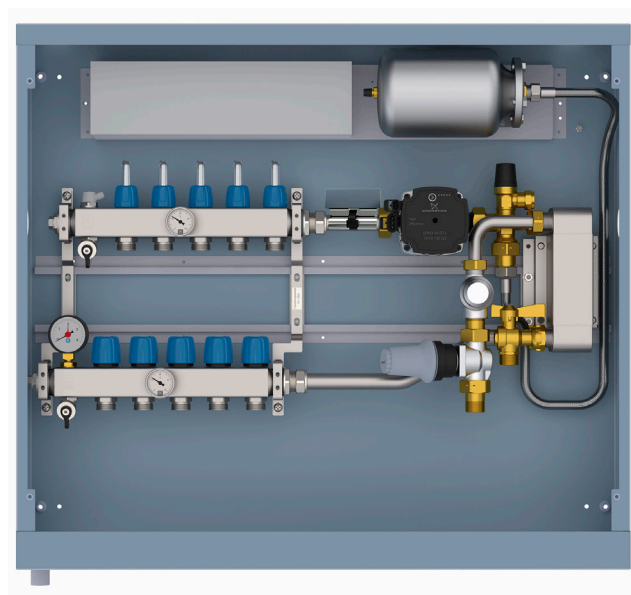

## DIMENSIONING

The following tables show the typical operational data for under floor heating and snow melting, showing the temperatures, flows and pressure for the primary and secondary sides with current output. If specific calculation is needed please contact LK Technical Support for assistance.

### Under floor heating Tprim 45°C, Tsek 40°/33°C

Output kW	1	2	3	4	5	6
Tprimary	45	45	45	45	45	45
Tprimary return	34,8	36,6	38,3	39,6	40,7	41,5
Tsecondary	40/33	40/33	40/33	40/33	40/33	40/33
q primary kg/s	0,023	0,057	0,107	0,176	0,277	0,415
q secondary kg/s	0,037	0,073	0,110	0,147	0,183	0,220
Pressure primary kPa	0,06	0,31	1,03	2,67	6,34	13,67
Pressure secondary kPa	0,13	0,45	0,97	1,67	2,58	3,65

### Under floor heating Tprim 55°C, Tsek 40°/33°C

Output kW	1	2	3	4	5	6	7	8	9	10
Tprimary	55	55	55	55	55	55	55	55	55	55
Tprimary return	33,4	33,8	35,0	36,4	37,7	38,5	39,2	39,8	40,3	40,8
Tsecondary	40/33	40/33	40/33	40/33	40/33	40/33	40/33	40/33	40/33	40/33
q primary kg/s	0,011	0,023	0,036	0,052	0,069	0,087	0,106	0,126	0,146	0,168
q secondary kg/s	0,037	0,073	0,110	0,147	0,183	0,220	0,257	0,293	0,330	0,367
Pressure primary kPa	0,02	0,05	0,13	0,26	0,45	0,70	1,01	1,39	1,87	2,43
Pressure secondary kPa	0,13	0,45	0,97	1,68	2,58	3,65	4,90	6,32	7,91	9,67

### Under floor heating Tprim 60°C, Tsek 40°/33°C

Output kW	1	2	3	4	5	6	7	8	9	10
Tprimary	60	60	60	60	60	60	60	60	60	60
Tprimary return	33,2	33,5	34,24	35,33	36,58	37,6	38,2	38,8	39,3	39,8
Tsecondary	40/33	40/33	40/33	40/33	40/33	40/33	40/33	40/33	40/33	40/33
q primary kg/s	0,009	0,018	0,028	0,039	0,051	0,064	0,077	0,090	0,104	0,118
q secondary kg/s	0,037	0,073	0,110	0,147	0,183	0,220	0,257	0,293	0,330	0,367
Pressure primary kPa	0,01	0,04	0,08	0,15	0,25	0,39	0,55	0,74	0,97	1,24
Pressure secondary kPa	0,13	0,45	0,97	1,68	2,57	3,65	4,89	6,32	7,91	9,67

### Snow melting/Ground heating Tprim 40°C, Tsek 35°/20°C

Output kW	5	6	7	8
Tprimary	40	40	40	40
Tprimary return	32,8	33,9	35,2	36,3
Tsecondary	35/20	35/20	35/20	35/20
q primary kg/s	0,166	0,236	0,347	0,517
q secondary kg/s	0,086	0,103	0,121	0,138
Pressure primary kPa	2,40	4,69	9,8	20,93
Pressure secondary kPa	0,62	0,87	1,17	1,51



Snow melting/Ground heating T<sub>prim</sub> 45°C, T<sub>sek</sub> 40°/25°C

Output kW	5	6	7	8
T <sub>primary</sub>	45	45	45	45
T <sub>primary return</sub>	37,3	38,8	40,1	41,2
T <sub>secondary</sub>	40/25	40/25	40/25	40/25
q primary kg/s	0,156	0,231	0,340	0,507
q secondary kg/s	0,086	0,103	0,120	0,137
Pressure primary kPa	2,13	4,47	9,33	19,97
Pressure secondary kPa	0,61	0,86	1,15	1,48

Snow melting/Ground heating T<sub>prim</sub> 50°C, T<sub>sek</sub> 45°/30°C

Output kW	5	6	7	8
T <sub>primary</sub>	50	50	50	50
T <sub>primary return</sub>	42,2	43,7	45,0	46,1
T <sub>secondary</sub>	45/30	45/30	45/30	45/30
q primary kg/s	0,154	0,227	0,334	0,497
q secondary kg/s	0,085	0,103	0,120	0,137
Pressure primary kPa	2,05	4,31	8,96	19,21
Pressure secondary kPa	0,60	0,85	1,13	1,46

Snow melting/Ground heating T<sub>prim</sub> 55°C, T<sub>sek</sub> 50°/35°C

Output kW	5	6	7	8
T <sub>primary</sub>	55	55	55	55
T <sub>primary return</sub>	50/35	50/35	50/35	50/35
T <sub>secondary</sub>	47,1	48,6	49,9	51,1
q primary kg/s	0,151	0,224	0,330	0,491
q secondary kg/s	0,085	0,102	0,119	0,136
Pressure primary kPa	1,98	4,17	8,71	18,67
Pressure secondary kPa	0,59	0,83	1,12	1,44





## DIMENSIONS

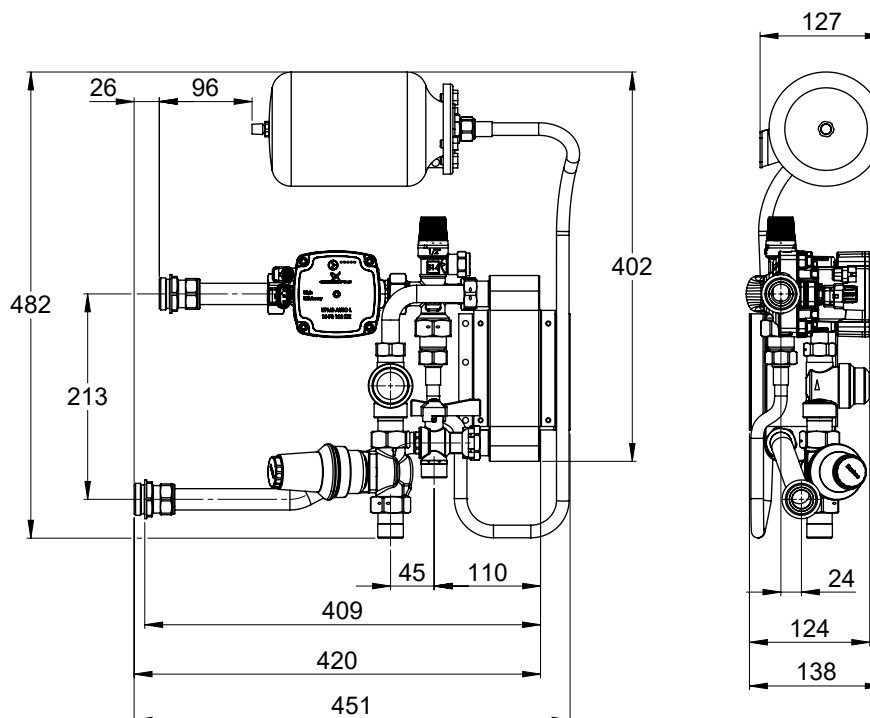

## TECHNICAL DATA

Article no.	241 88 10
Working pressure prim	Max 6 bar
Pressure Difference prim	Max 60 kPa
Working temperature prim	Max 80 °C
Working pressure sec	Max 2,5 bar
Working temperature sec	Max 50 °C
Control valve	Danfoss RA-C 20, Kvs 3,2
Thermostat	Danfoss FTC
Operating temperature	15-50 °C
Storage temperature	max 40 °C
Glycol content	max 50%
Circulation pump	Grundfos UPM3 Auto 15-70 with cast iron pump casing
Relay	1 phase 230V AC, -15 % / +10 %, 50 Hz, PE
Output	Max 45 W
Current	Max 0,38 A
Protection Class	IP 42
Isolation class	F
Humidity level	Max 95 %
Heat Exchanger	Stainless steel AISI 316, E5THx20/1P-SC-S
Connecting pipes	Stainless steel
Connecting tubes	Galvanised wire braided EPDM tube
Expansion pipe	2 litre
Safety valve	LKA 514, 2,5 bar conn. Cu 15
Dirt filter	PN 16, filter size 0,8 mm, Kvs 5,5

